

# PILOT OPERATED CHECK - ZRE

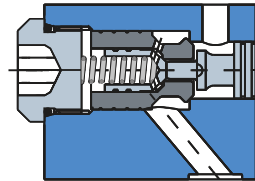

- Max. operating pressure 350 bar
- Max. flow 120 l/min
- Opening ratio 1 : 6 (pilot cone /main cone)
- Cracking pressure 2 bar (check valve)
- Viscosity range 10 ... 500 cSt
- Fluid temperature range -18 ... + 60°C



Seal kit for  
ZRE... D1 = 098-91090-0  
ZRE... D5 = 098-91091-0

## ORDERING CODE :

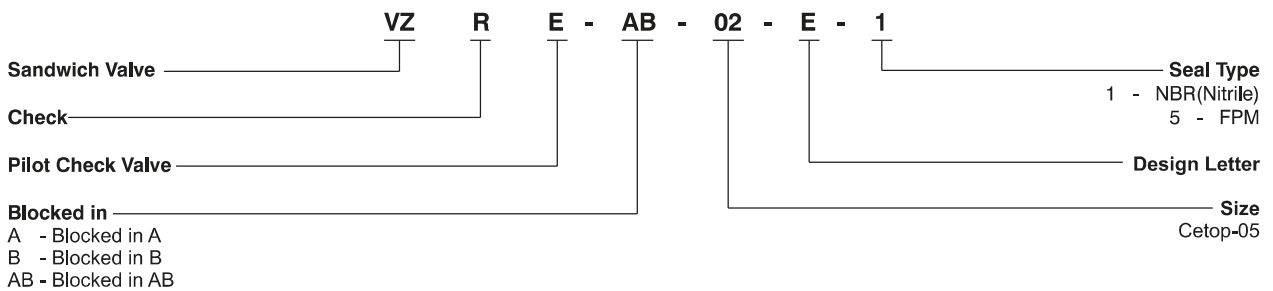

### BLOCKED IN A AND B

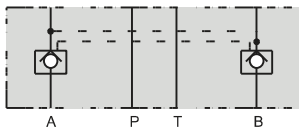

Model code: ZRE-AB02-D1  
Order No. 098-91300-0

### BLOCKED IN A

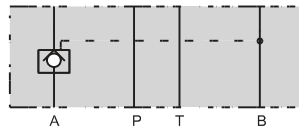

Model code: ZRE-A02-D1  
Order No. 098-91298-0

### BLOCKED IN B

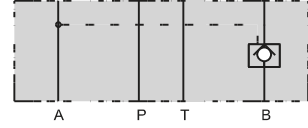

Model code: ZRE-B02-D1  
Order No. 098-91304-0

## INSTALLATION - 3.1 kg

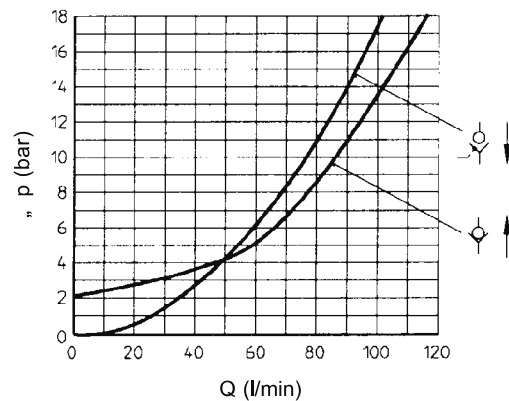
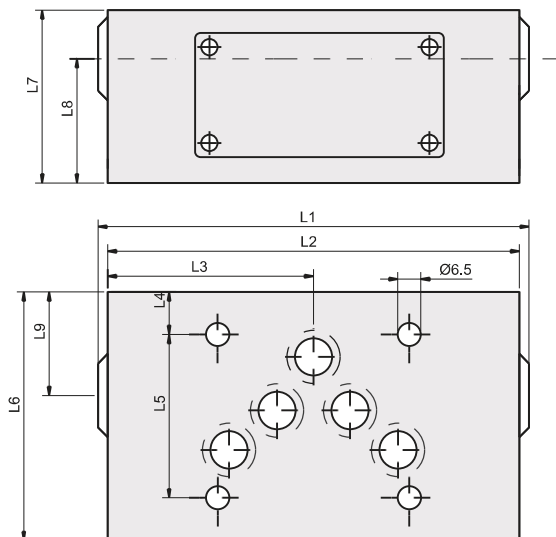

### SERVICE INFORMATION:

MODEL CODE	SPARE PART NO.	DETAILS
VZRE.....D1	V098-91090-0	SEALKIT
VZRE.....D5	V098-91091-0	SEALKIT

UNITS	L1	L2	L3	L4	L5	L6	L7	L8	L9
mm	117.0	116.0	58.0	12.0	46.0	70.0	50.0	35.0	28.5
in	4.60	4.56	2.28	0.47	1.81	2.75	1.97	1.38	1.12

NOTE : When service of this valve is necessary, it should be replaced as a complete unit as the internal components form a matching set (not applicable to the seal kit).